

Pylon design, landscape and acceptance

POWER PYLONS OF THE FUTURE

Henrik Skouboe, CEO

hs@bystrup.dk



Specializing in Pylon design

More than 15 years of practical experience

Energized lines using new pylon design

Global activities and projects

Turn key Consulting / EPC

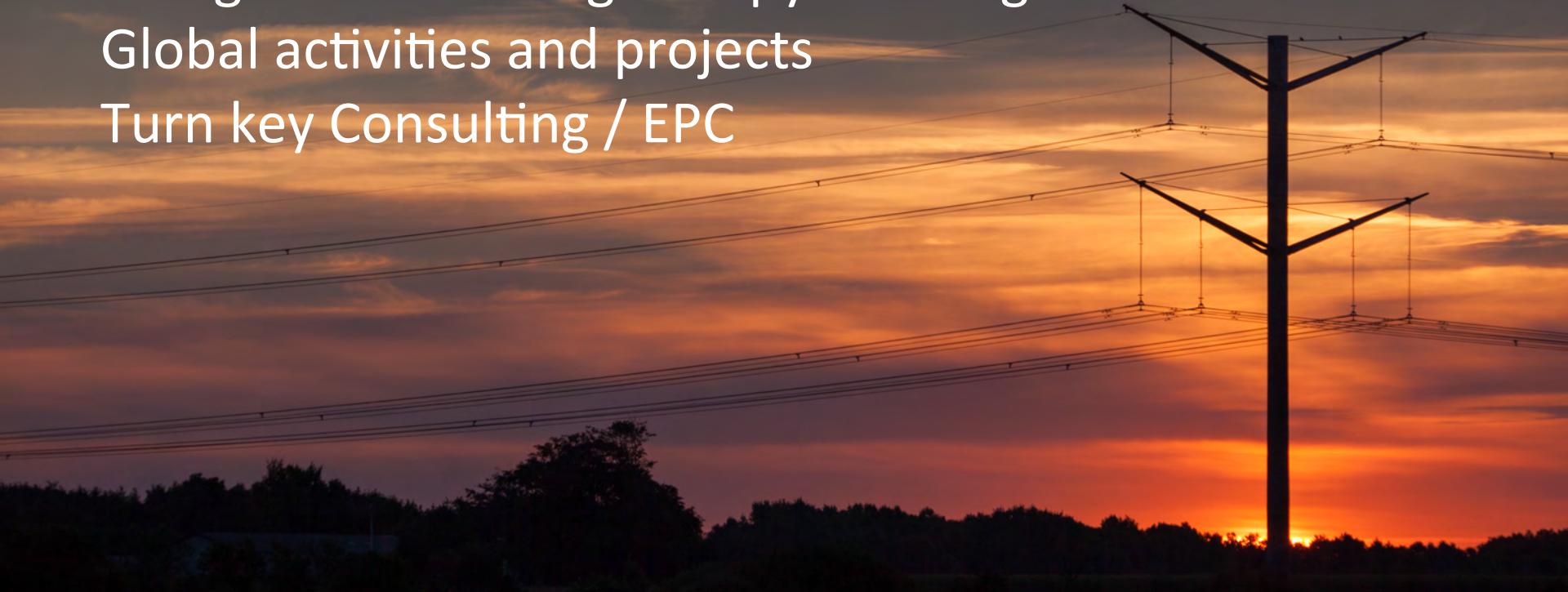

The product of the last 100 years



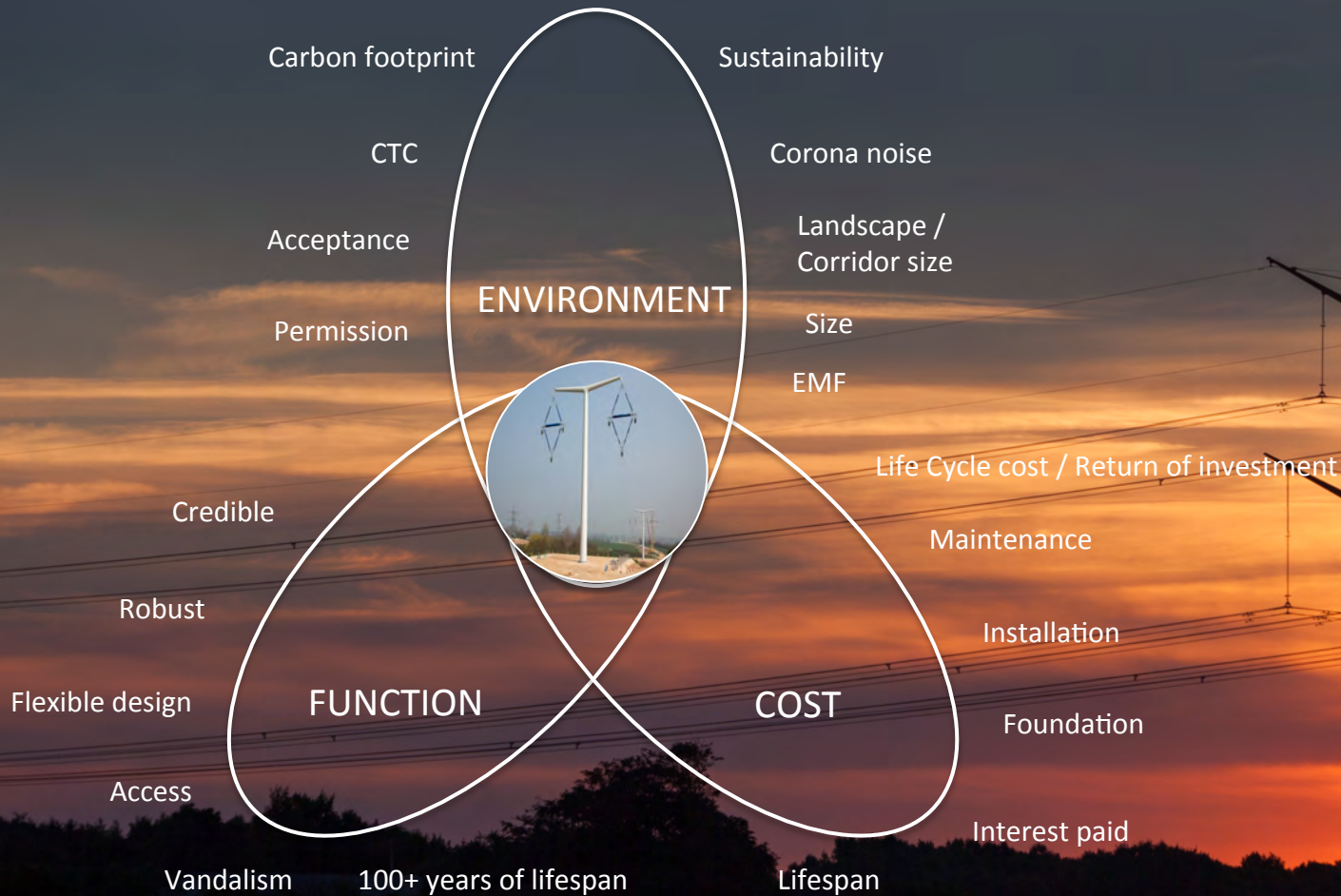

BYSTRUP

The transformation is inevitable



BYSTRUP

GETTING POSITIVE FEEDBACK

80 pylons energized in 2006

1x400kV

Energinet.dk

Denmark



BYSTRUP



BYSTRUP



Political agreement November 2008

Future OHTL

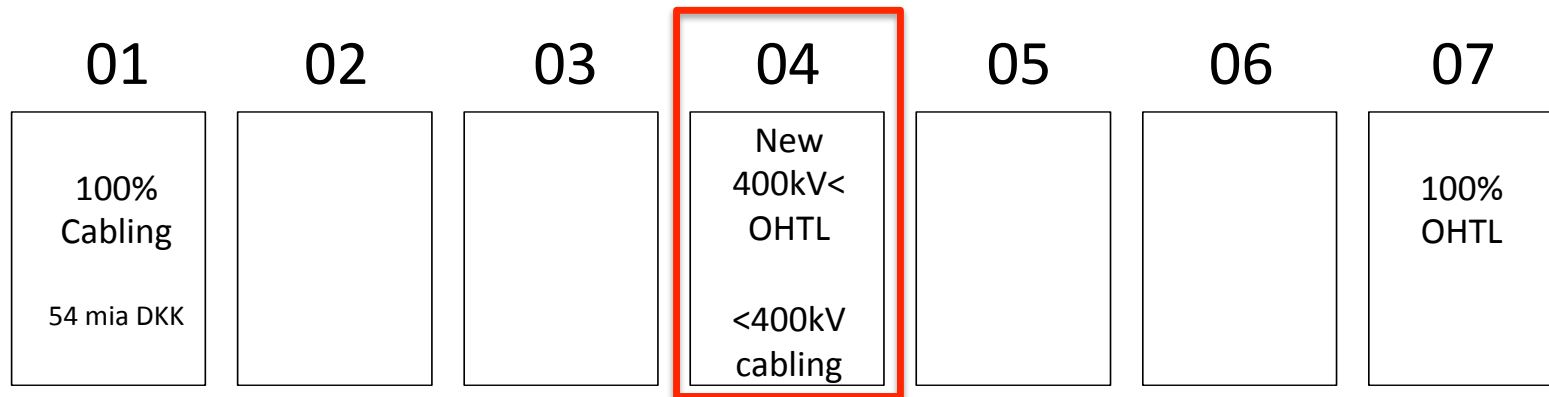

GETTING PERMISSION

Improved image

506 pylons energized in 2014

2x400kV

Energinet.dk

Denmark



THE EAGLE PYLON PROJECT TIME LINE

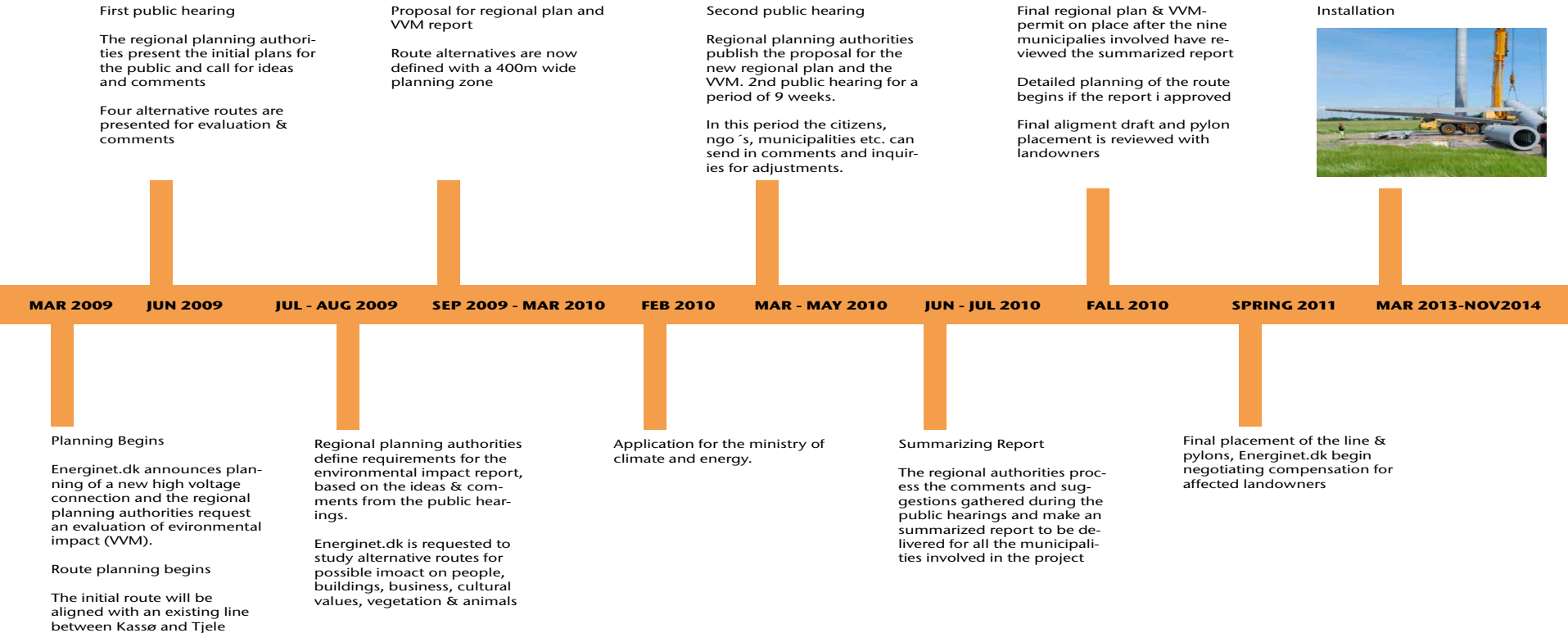

“ The undertaking of the Eagle Pylon has shown that it is possible to rethink the design - and get positive feedback. ”

- Christian Jensen, Executive Project Manager,
Energinet.dk



“The challenge is to design a pylon that has the potential to deliver for future generations, whilst balancing the needs of our communities and preserving the beauty of our countryside”

Competition Brief May 23rd 2011



“There was one unanimous Winner”

Source: National grid

The T-Pylon

Oct. 2011



T-Pylon
Nationalgrid

Eakring 2015
Hinkley 2017



PUBLIC ACCEPTANCE

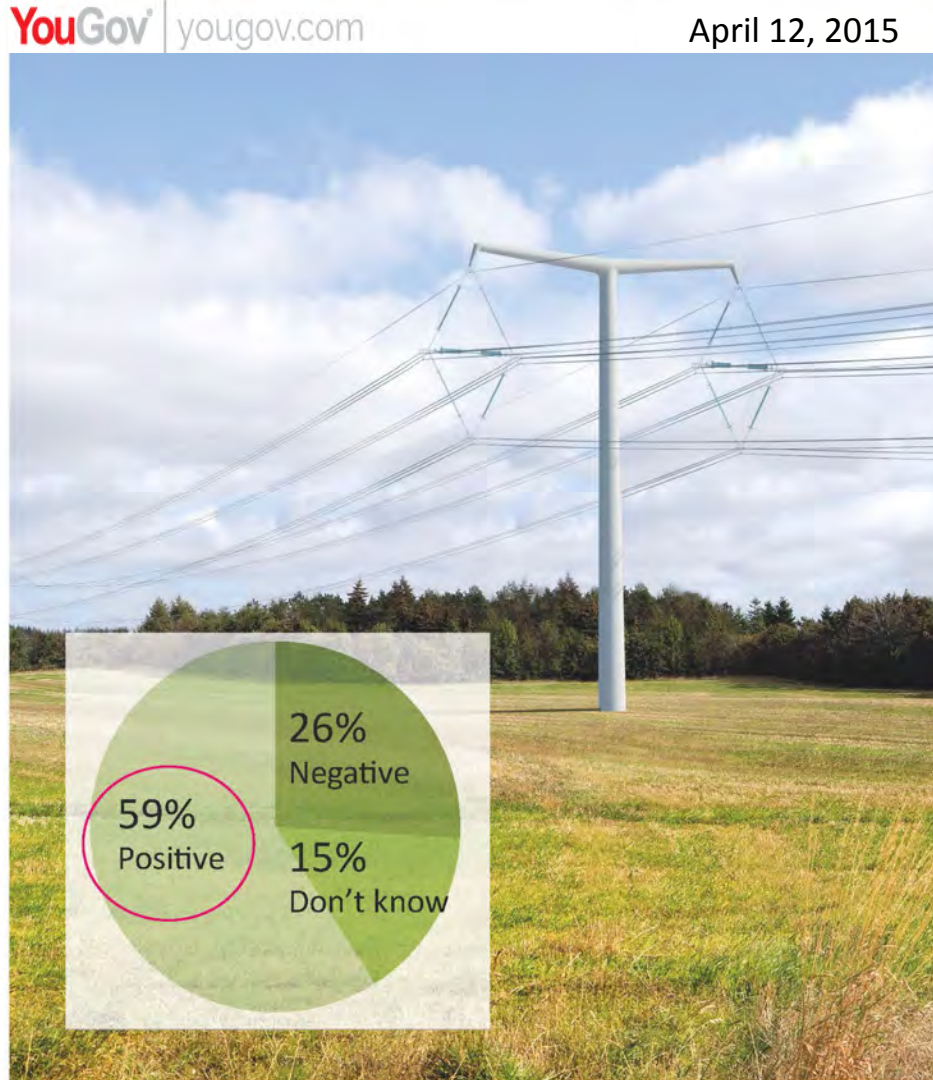
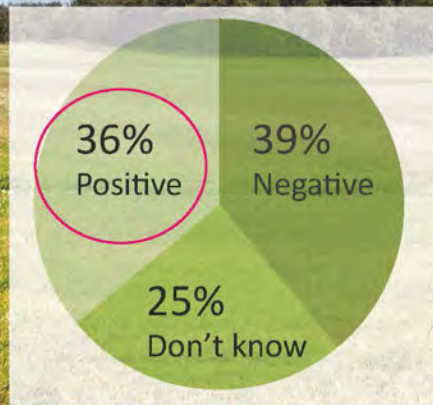
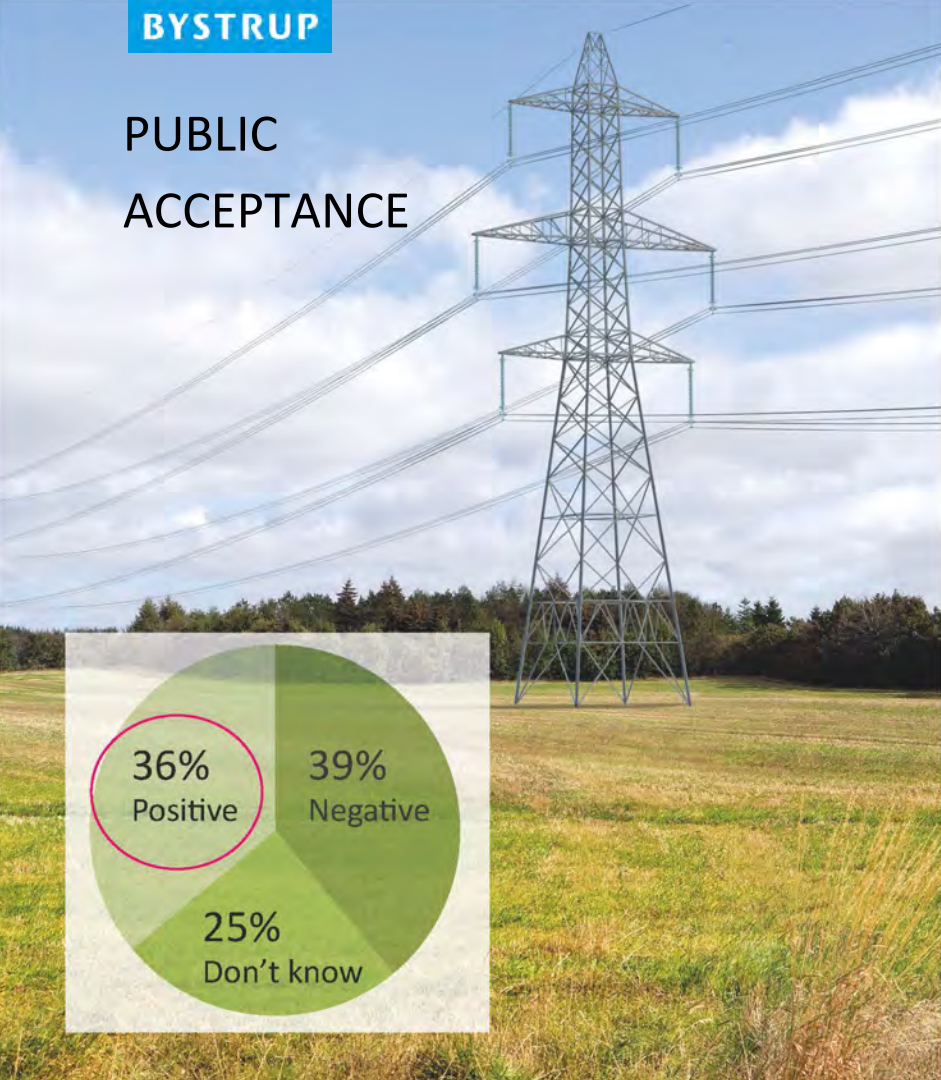

BYSTRUP

REDUCED
SIZE

56m



24m

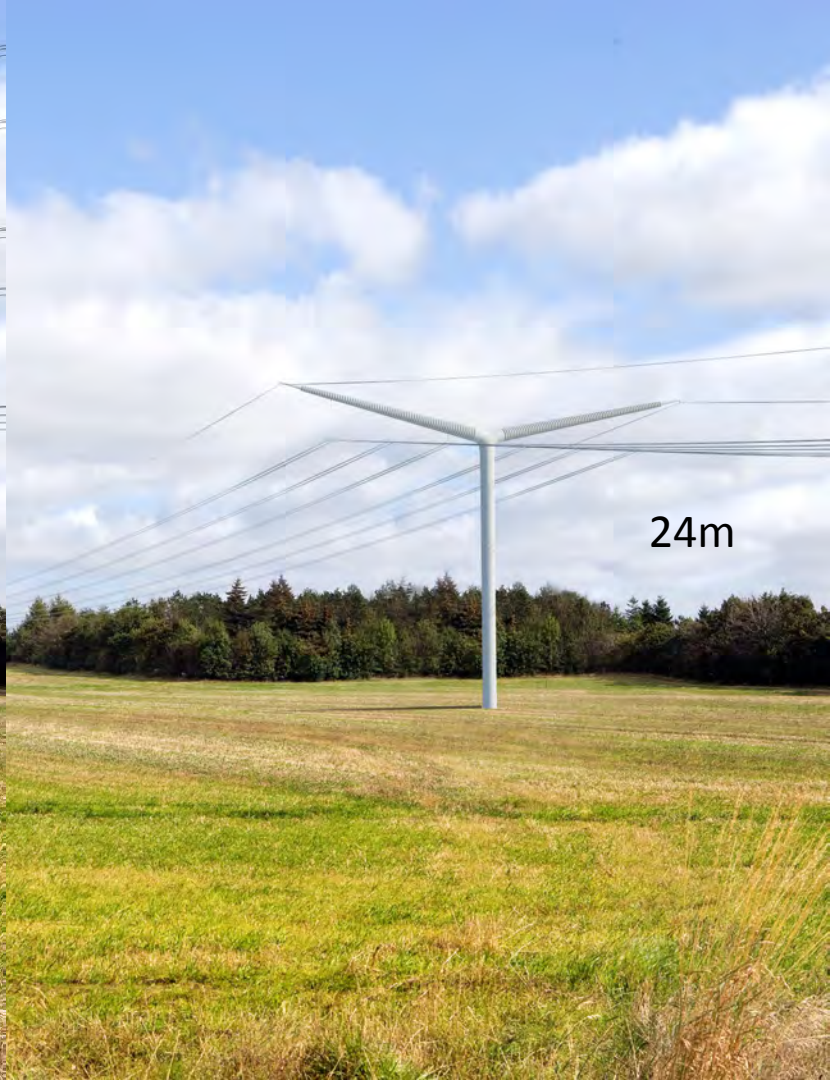



BYSTRUP

REDUCED CORRIDOR

2X400kV



We have challenged every aspect



Minimal size

Cost

EMF

Materials

Nature conservation

Production methods

Installation

Vandalism

Assembly/Erection

Visual impact

Maintenance

Health and Safety

BYSTRUP

SIMPLE INSTALLATION

ONE TEAM

ONE DAY

ONE PYLON



SIMPLE FOUNDATION



New pylon foundation using a monopile
(1 DAY)



Lattice tower foundation
(21+ DAYS)

BYSTRUP

REDUCED FOOTPRINT



REDUCED EMF

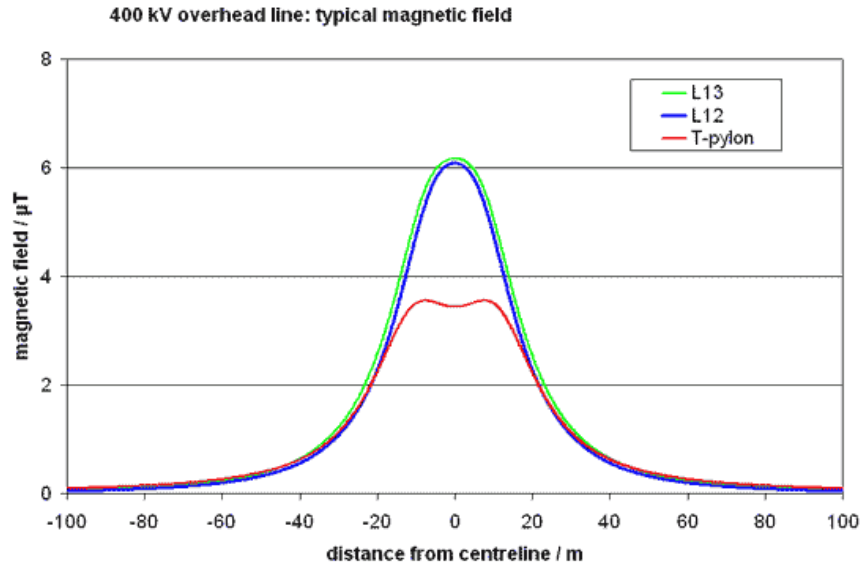

Source: Emfs.info

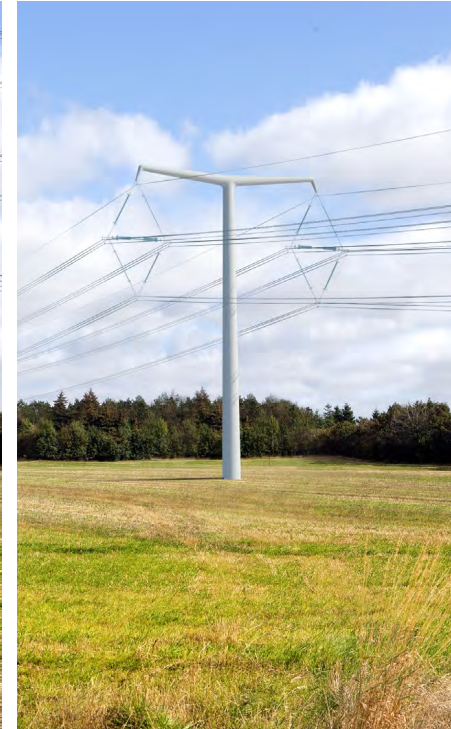

FAMILY OF TOWERS



Suspension



Flying angle <math>< 10^\circ</math>



Tension <math>< 30^\circ</math>

LIFE CYCLE COSTS

- **Planning**

Getting permission or not?

Compensation

- **Construction**

Production

Installation

Transport

- **Operation**

Maintenance

Vandalism

- **Financing**

Interest paid

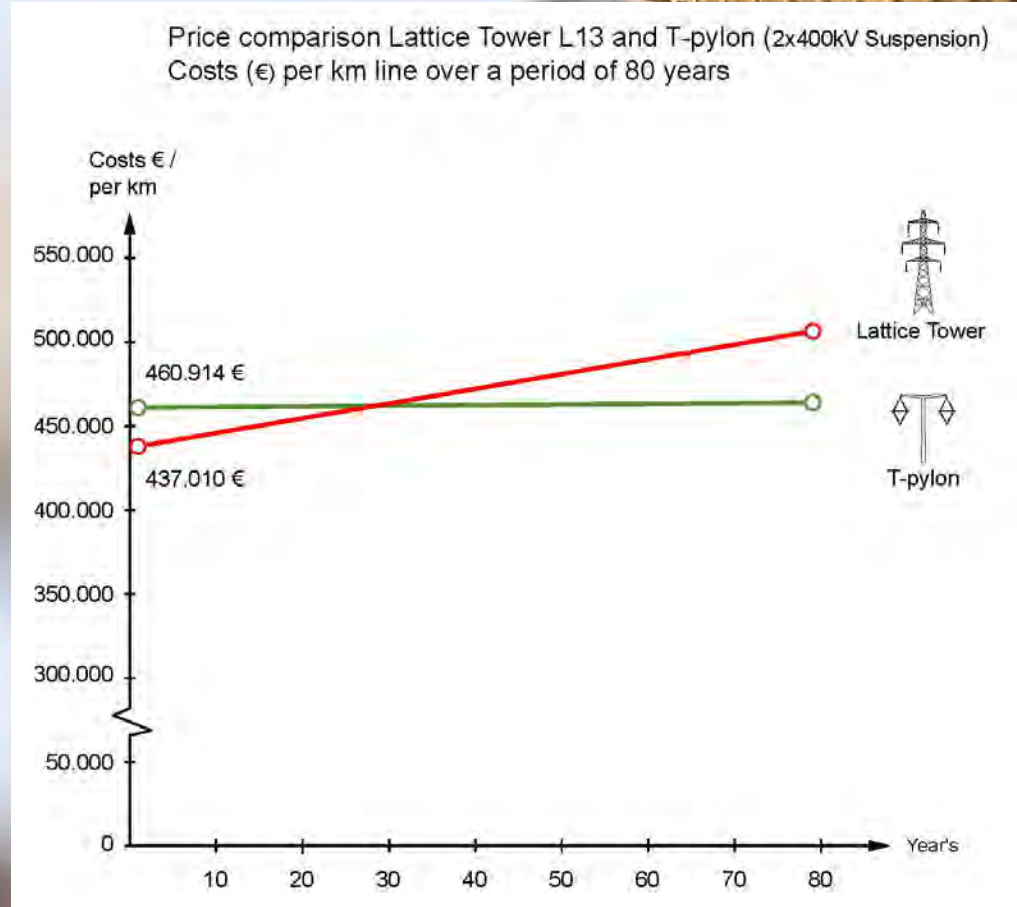

BYSTRUP

The transformation is coming

more information:

www.powerpylons.com

hs@bystrup.dk

